

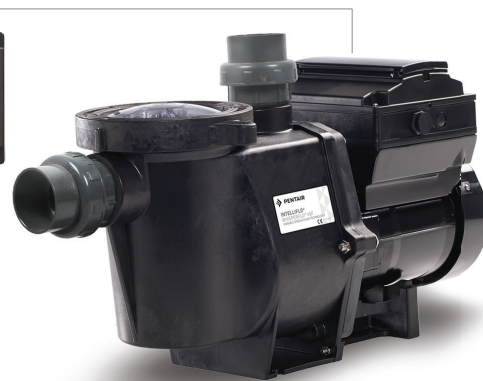

70-120 M³



VSF DISPLAY



WHISPERFLO® VSF

First-in-class hydraulic performances, modern design for the highest efficiency at low speed with very low energy consumption.

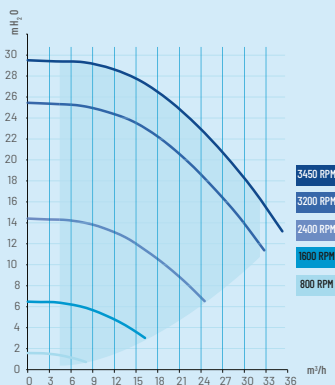

FEATURES

- ¼ turn opening lid
- Quick self priming
- One-piece pump body
- Built-in diagnostics

BENEFITS

- Easy opening and locking
- Quick and safe start of the pump
- Super silent
- Protect the pump for longer service life

TECHNICAL FEATURES

- 3hp permanent magnet motor, made in Italy, improved efficiency
- 8 programmable speed/time - simplified menus
- Rotatable LCD display / optional wall-mounting kit (PN. R356905)
- Real time clock with 24hrs retention
- TradeGrade exclusivity, only available on Whisper and XF lines
- RS485 Modbus communication / Optional control cable (PN. R350122)
- Inlet/Outlet → 2" BSP tapped
- Ø Unions → 50 mm or 63 mm
- Unions included → VS2 and VSF
- Salt resistancy → 0.40%

Part Number	Flow m ³ /h @ 8 m	Power output (kW)	(HP)	Volt (V)	Phase	Width (mm)	Length (mm)	Weight (Kg)	List Price (€ VAT excl)
WFL-VSF	39	2.2	3	220-240	1~	275	594	23	1799

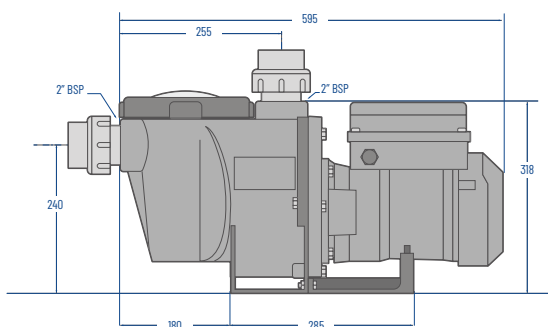

Packaging	Length (cm)	Width (cm)	Height (cm)	Pallet
Box	65	32	36	-
Pallet	120	120	150	18